

Orion® Premium 110mm f/7.0 ED Refractor

#9206 Optical Tube Assembly



Figure 1. The Premium 110mm f/7.0 ED Refractor optical tube assembly

Congratulations on your purchase of an Orion Premium 110mm f/7.0 ED refractor optical tube. Your telescope has been designed with high quality optics and excellent mechanical construction. The ED glass in the objective lens means you'll enjoy images with far less chromatic aberration than those seen in a standard refractor, and the smooth dual-speed Crayford focuser will make getting sharp images a breeze. These instructions will help you set up and use your telescope.

Getting Started

The Premium 110mm f/7.0 ED comes fully assembled from the factory. The telescope's optics have been installed and collimated, so you should not have to make any adjustments to them.

Please keep the original shipping box! In the unlikely event you should need to ship the telescope back to Orion for warranty repair service, you should use the original packaging.

The box also makes a very good container for storing the telescope when it is not in use.

Mounting the Telescope

The Premium 110mm ED refractor can be mounted on Orion equatorial mounts using the included tube rings and dovetail mounting plate. The dovetail mounting plate connects directly to the equatorial mount's dovetail holder. The dovetail holder has two securing knobs to keep the dovetail plate securely in place. Be sure to loosen these two knobs prior to connecting the telescope to the mount. While grasping the telescope firmly, place the dovetail mounting plate into the mount's dovetail holder and tighten the clamping knobs to secure the optical tube.

An equatorial mount is desirable for astronomical viewing as it allows easy manual and/or motorized electronic tracking of celestial objects as the Earth rotates. Setting circles on equatorial mounts also enable you to locate objects by their cele-



Customer Support (800)-676-1343
E-mail: support@telescope.com

Corporate Offices (831)-763-7000
 89 Hangar Way, Watsonville, CA 95076

tial coordinates (right ascension and declination), which can be found in many observing books and star atlases.

The Premium 110mm ED refractor can also be easily mounted on altazimuth mounts, like the Orion VersaGo, which utilize a dovetail holder like Orion equatorial mounts.

Extendable Lens Shade

The Premium 110mm ED refractor features an extendable lens shade that can help prevent dew accumulation on the objective lens as well as block stray light or glare from entering the telescope. Once you have mounted the telescope, gently pull forward on the lens shade to extend it. Tighten the lens shade thumbscrew to secure the lens shade to the desired position. Be careful to not touch the objective lens. The lens shade should be retracted during storage or at times when the telescope is not in use. Remember to loosen the lens shade thumbscrew before making any adjustments.

Use of Optional Eyepieces, Diagonal, and Finder Scope

The Premium 110mm ED does not come with a finder scope, diagonal or eyepieces in order to grant the user the greatest versatility in customizing the instrument to suit their tastes. However, certain rules for using accessories still apply.

You can attach an optional Orion finder bracket to the 110mm ED using the included dovetail mounting base which has been pre-installed on the optical tube (Figure 2). To attach a finder bracket simply loosen the knurled thumbscrew on the side of the bracket, slide the foot of the finder scope bracket completely into the dovetail and re-tighten the thumbscrew to secure it into place. Any Orion finder scope with a dovetail bracket will fit into the dovetail mounting base.

The Premium 110mm ED refractor can use almost any 2" diagonal and eyepiece. To install a diagonal, unthread the thumbscrew on the focuser drawtube (Figure 2) until the internal brass ring is flush with the interior of the drawtube. Insert the diagonal and secure it with the thumbscrew, which will compress the brass ring around the inserted barrel of the diagonal. Then insert an eyepiece into the diagonal and secure it with the thumbscrew(s) on the diagonal.

The 2" Dual-Speed Crayford Focuser

The Premium 110mm ED comes equipped with a dual-speed Crayford focuser. The Crayford design allows for smooth, precise focusing without any image shift that typical rack-and-pinion designs experience.

The focuser features dual-speed adjustment with the fine focus wheel (Figure 2). This small black wheel allows precise focus adjustment at a ratio of 11:1, meaning eleven turns of the fine focus wheel equals one turn of the focus wheel. Use the focus wheels to achieve rough focus on your target object, then use the fine focus wheel for the most precise focus in order to coax out even more image detail. You'll be amazed at the amount of detail fine focus adjustments allow you to view on targets such as the lunar surface, planets, star clusters, and other celestial objects.

If you find that the focus wheels are too tight or too loose, you can make adjustments to the drawtube tension by using the

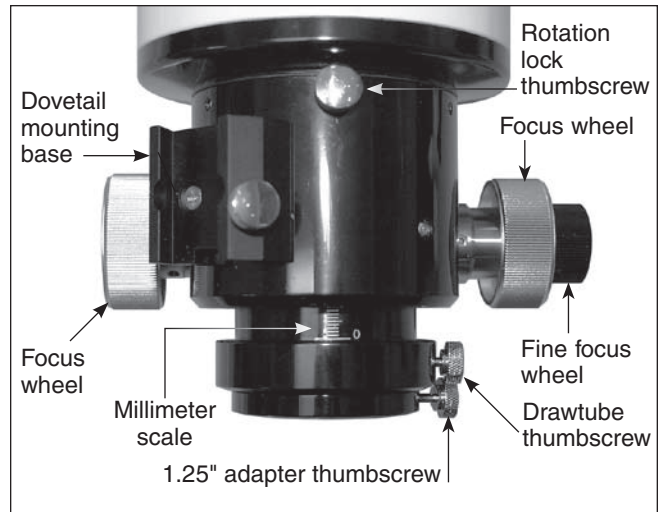

Figure 2. The 2" dual-speed Crayford focuser

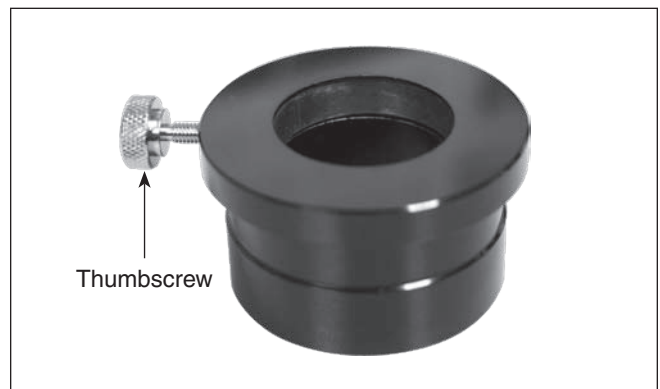

Figure 3. The 1.25" eyepiece adapter

drawtube tension adjustment set screw located on the bottom of the focuser between the focus wheels. Make adjustments to this set screw with the provided hex key until the focuser motion feels comfortable. Please note that you must have at least some tension applied to the focuser drawtube or else it will not move when you turn the focus wheels.

Once you have achieved focus, you can lock the focuser in place by tightening the focus lock thumbscrew located on the bottom of the focuser between the focus wheels (Figure 1). Locking the focuser in place can be especially useful for imaging applications. Be sure to loosen the focus lock thumbscrew before making additional focus adjustments.

The focuser drawtube is labeled with a millimeter scale to be used as a reference (Figure 2). This scale can be useful to quickly reach focus on previously viewed objects. When initially observing (or imaging) an object with the Premium 110mm ED, make a note of the scale position once the object is in focus. When you view the same object during a different observing session, you can quickly reach focus by setting the millimeter scale to the previously noted position.

A useful feature of the focuser is that it can be rotated relative to the tube. This enables you to customize the orientation of the focus wheels to the most convenient position. To rotate,

loosen the focuser rotation lock thumbscrew (Figure 2) by a few turns while holding the focuser steady. Adjust the orientation of the focuser and then tighten the focuser rotation lock thumbscrew to secure the desired position

Use of 1.25" Eyepieces and Diagonals

If you wish to use 1.25" eyepieces and/or a 1.25" diagonal with the Premium 110mm ED, the 1.25" eyepiece adapter is required (Figure 3). 1.25" eyepieces usually allow higher magnification than 2" eyepieces. This is especially desirable for high power observation of objects in our solar system such as the Moon and planets.

To use 1.25" accessories, simply insert the 1.25" eyepiece adapter into the drawtube as you would a 2" accessory. Be sure to secure the adapter in place with the thumbscrew on the drawtube. You can now insert a 1.25" accessory into the adapter for use.

Calculating Magnification (Power)

It is desirable to have a range of eyepieces of different focal lengths, to allow viewing over a range of magnifications. To calculate the magnification, or power, of a telescope, simply divide the focal length of the telescope by the focal length of the eyepiece:

$$\text{Telescope F.L.} \div \text{Eyepiece F.L.} = \text{Magnification}$$

For example, the Premium 110mm ED, which has a focal length of 770mm, used in combination with a 25mm eyepiece, yields a power of 30.8x.

$$770 \div 25 = 30.8X$$

Every telescope has a useful limit of power of about 2x per millimeter of aperture. Claims of higher power by some telescope manufacturers are a misleading advertising gimmick and should be dismissed. This means the highest useful magnification for the Premium 110mm ED is approximately 220x. Keep in mind that at higher powers, an image will always be dimmer and less sharp (this is a fundamental law of optics). The steadiness of the air (the "seeing") will also limit how much magnification an image can tolerate.

Always start viewing with your lowest-power (longest focal length) eyepiece in the telescope. After you have located and observed the object with it, you can try switching to a higher-power eyepiece to ferret out more detail, if atmospheric conditions permit. If the image you see is not crisp and steady, reduce the magnification by switching to a longer focal length eyepiece. As a general rule, a small but well-resolved image will show more detail and provide a more enjoyable view than a dim and fuzzy, overmagnified image.

Note About Chromatic Aberration

Whenever light passes through one material to another, light of different wavelengths (color) is bent by different amounts. This is a problem that plagues refractor-type telescopes, since light passes through both air and glass to form an image. Most astronomical objects emit a spectrum comprised of many different wavelengths of light, so each wavelength will be bent by a slightly different amount when passing through a lens. This results in each color of light reaching precise focus at a slightly different point, which reduces image sharpness.

The Premium 110mm ED is designed to minimize chromatic aberration. The objective lens comprises two individual lens elements, one of which is made of "ED" (Extra-low Dispersion) glass, a special type of glass that has superior refractive properties compared to normal types of glass. The use of this ED glass minimizes the amount of chromatic aberration, resulting in a cleaner, sharper image compared to that in standard achromatic refractors.

Imaging with the Premium 110mm ED Refractor

The Premium 110mm ED refractor's f/7.0 optics make it an excellent choice for astro-imaging. The telescope has been designed with plenty of inward focus travel. This is a great convenience for many imaging applications which require additional devices, such as off-axis guiders and filter wheels, between the telescope and camera. Without additional inward focus travel, these devices would be difficult, if not impossible, to use. As a consequence of this, extension tubes may be necessary to reach focus with a camera if no other devices are placed between the telescope and camera.

Using a digital SLR camera with the telescope requires a T-ring for your model of camera and a 2" camera adapter. A 2" extension tube may also be required.

To use the Premium 110mm ED with the Orion StarShoot imaging cameras, an extension tube will generally be required. No other camera adapters should be needed. Please go to OrionTelescopes.com for details.

Care & Maintenance

Give your telescope reasonable care and it will last a lifetime. When not in use, keep its dust cover on as well as the dust cap for the eyepiece opening. Store it indoors or in a dry garage. Do not leave the telescope outside when not in use.

Orion offers a foam-lined hard case for the Premium 110mm ED refractor which is an excellent choice for both storage and safe transport of the telescope. Please go to OrionTelescopes.com for details.

The optical tube is aluminum and has a smooth painted surface that should resist scratches and smudges. If a scratch does appear on the tube, it will not harm the telescope. Smudges on the tube can be wiped off with standard household surface cleaners.

Any quality optical lens tissue and cleaning fluid specifically designed for multi-coated optics can be used to clean the telescope's objective lens as well as the lenses of eyepieces and finder scopes. Never use regular glass cleaner or cleaning fluid designed for eyeglasses. Before cleaning with fluid and tissue, blow any loose particles off the lens with a blower bulb or compressed air, or lightly brush the lens with a soft camel hair brush. Apply some cleaning fluid to a tissue, never directly on the optics. Wipe the lens gently in a circular motion, then remove any excess fluid with a fresh lens tissue. Oily fingerprints and smudges may be removed using this method. Use caution; rubbing too hard may scratch the lens! Clean only a small area at a time, using a fresh lens tissue on each area. Never reuse tissues.

Specifications

Objective lens diameter:	110mm (4.3")
Objective lens:	Air-spaced doublet, one element made of ED glass
Objective lens coating:	Fully multi-coated
Focal length:	770mm
Focal ratio:	f/7.0
Lens cell:	Machined aluminum
Focuser:	Crayford, accepts 2" accessories, dual-speed focus adjustment, rotatable
1.25" adapter:	Included, threaded for 2" filters
Optical tube:	Seamless aluminum
Tube interior:	3x baffles, painted flat black
Mounting provision:	Tube rings (2) and dovetail mounting plate included
Weight:	10 lbs. 1 oz.
Length:	25.1"
Hard Case:	Optional

One-Year Limited Warranty

This Premium 110mm f/7.0 ED Refractor is warranted against defects in materials or workmanship for a period of one year from the date of purchase. This warranty is for the benefit of the original retail purchaser only. During this warranty period Orion Telescopes & Binoculars will repair or replace, at Orion's option, any warranted instrument that proves to be defective, provided it is returned postage paid to: Orion Warranty Repair, 89 Hangar Way, Watsonville, CA 95076. If the product is not registered, proof of purchase (such as a copy of the original invoice) is required.

This warranty does not apply if, in Orion's judgment, the instrument has been abused, mishandled, or modified, nor does it apply to normal wear and tear. This warranty gives you specific legal rights, and you may also have other rights, which vary from state to state. For further warranty service information, contact: Customer Service Department, Orion Telescopes & Binoculars, 89 Hangar Way, Watsonville CA 95076; (800)-676-1343.

Orion Telescopes & Binoculars

89 Hangar Way, Watsonville CA 95076

Customer Support Help Line (800)-676-1343 • Day or Evening