

Orion® StarShoot™ Autoguider PRO

#52031



 **ORION**
TELESCOPES & BINOCULARS
AN EMPLOYEE-OWNED COMPANY

Corporate Offices: 89 Hangar Way, Watsonville CA 95076 - USA

Toll Free USA & Canada: (800) 447-1001

International: +1(831) 763-7000

Customer Support: support@telescope.com

Copyright © 2020 Orion Telescopes & Binoculars. All Rights Reserved. No part of this product instruction or any of its contents may be reproduced, copied, modified or adapted, without the prior written consent of Orion Telescopes & Binoculars.

Congratulations on your purchase of the Orion StarShoot Autoguider PRO (**SAGPRO**).

The **SAGPRO** is a high speed CMOS camera designed for astronomical use.

The light weight, slim form factor, high sensitivity and built in **ST4 port** make the **SAGPRO** ideal for use as a guide camera.

The ultra-fast frame rate (up to **200FPS** in lowest resolution and up to **30FPS** in highest resolution) makes the **SAGPRO** ideal for Solar system imaging (Planets, Moon, Sun).

Long exposures of up to **10 Minutes** make the **SAGPRO** capable of imaging many of the Deep Space objects such as Galaxies, Nebulas, and Clusters.

In summary the **SAGPRO** can be used for the following purposes:

- Auto Guiding
- Planetary Imaging
- Lunar Imaging
- Solar Imaging
- Deep Space Imaging

Parts List

- StarShoot Autoguider PRO mono camera (**SAGPRO**)
- Par Focal Ring and thumbscrew
- 1.25" Nosepiece
- USB Cable
- Autoguider cable
- Software Download Insert card
- Manual

Par Focal Ring

Attach the ring to the body of the **SAGPRO** and position as desired and lock using thumb screw. The ring aids in preventing the **SAGPRO** from falling too far into a focuser and also helps to match the **SAGPRO** focus position to an eyepiece. To do this first focus as normal using your eyepiece, then replace the eyepiece with the **SAGPRO** camera and move **SAGPRO** manually by hand until image from camera is in focus. Lock the ring at this position so that camera and eyepiece are now close to matching focus.

1.25" Nosepiece

Attach the 1.25" nosepiece to the **SAGPRO**. The nosepiece is fitted with filter threads.

(Filters available through Orion, check the catalog or OrionTelescopes.com for more information).

Autoguider cable

Plug the autoguider cable into the ST4 port located on rear of the **SAGPRO** and also into guide port located on mount.

System Requirements

Computer

The **SAGPRO** requires a PC running Windows XP, Vista, 7 or 8. The computer hard-ware should have at least the following:

- Pentium™ III Processor
- CD-ROM
- Connection to the Internet
- 512MB RAM
- Disk Space – 10GB or more is recommended
- Video Display –16-bit color or higher, 1280 x 960 or higher is recommended
- Mouse
- USB High Speed 2.0 port

Software and Driver Installation

Before the **SAGPRO** can be used, software and camera drivers must be installed onto your computer.

Do not connect the camera to your computer before you have installed the -software.

All software, manuals and guides can be downloaded directly from the Orion SAGPRO product support page located at the link below:

www.telescope.com/sagpro

The following software can be located on the right hand side of the product support page.

1. Download and run SAGPRO Driver. Go through the prompts until the driver is installed.
2. Next download and run SAGPRO ASCOM Driver. Go through the prompts until the driver is installed.
3. Next download and run the ASCOM platform (unless previously installed) The ASCOM Platform is necessary to use the ASCOM driver with ASCOM compatible software. Check the ASCOM platform website listed below for updates and additional details.

<http://www.ascom-standards.org>

4. Next download and run PHD guiding. Go through the prompts until the guiding software is installed. Check PHD guiding website listed below for updates and additional details.

<http://www.stark-labs.com/phdguiding.html>

5. If you intend to use your camera also as a Lunar, Solar, Planetary or Deep Space imager, download and run ORION ASTROCAP. Go through the prompts until the capture software is installed.
6. Also located on the SAGPRO product support page is the Orion AstroCap Software guide. This guide is essential for Lunar, Solar, Planetary or Deep Space imagers to get the most out of the SAGPRO.



Figure 1. The **SAGPRO** setup for guiding using the Orion Mini 50mm Guide Scope.

Please note that to use **PHD guiding** or other **ASCOS** compatible software the **SAGPRO Driver**, **SAGPRO ASCOM** driver and the **ASCOS platform** must be installed first.

Installing the Camera

1. Once the software installation is complete from the previous steps, connect the **SAGPRO** to your computer's USB port using the provided USB cable.
2. In Windows XP a **Found New Hardware Wizard** will appear. Windows 7, 8 or Vista will automatically install the device.
3. Windows XP will ask if you want to search for drivers and updates online. Select **No, not this time** and click **Next**.
4. Next, choose **Install the software automatically**.

-
5. Windows may note that the driver has not passed Windows Logo testing. This is normal. Click the **Continue Anyway** button. When the Wizard has completed, click the **Finish** button.

Windows Vista, Windows 7 and Windows 8 will automatically detect and install the camera to your computer.

Camera Installation Troubleshooting Tip

If Windows is unable to automatically locate and install the camera (after you performed the driver installation), then install the drivers manually by doing the following:

1. With the camera plugged into the USB, go to the Device Manager from the Windows Control Panel.
2. Locate the “**Imaging devices**” device tree, and right click on the device “**SSAGPro**”.
3. Select “Update Driver Software”, then browse the file path to the directory you installed the drivers, the default is: **C:\Program Files(x86)\Orion\SSAGProDriver**

Using the SAGPRO with ASCOM Compatible Software

ASCOM platform 5 or later and the included **ASCOM driver** must be installed to use the camera with **PHD Guiding** or other **ASCOM** compatible software

1. Install the **SAGPRO Driver**, **SAGPRO ASCOM driver** and **ASCOM Platform** per the installation section of this manual.
2. Using supported **ASCOM** compatible software, such as **Nebulosity** or **MaxIm DL**, select **ASCOM** for the camera type.
3. From the **ASCOM** Camera Chooser, select **CMOS SSAGPro camera**.

Adjust the gain if necessary & turn **ON** or **OFF** 12bit mode via the properties.

Note: If using PHD guiding turn OFF 12 Bit mode.

Autoguiding

The **SAGPRO** is also a fully functional autoguider. The autoguider output is on-board the camera, allowing the autoguider cable to connect directly from the camera to your mount's autoguider port.

Primary Telescope/ Main Imaging Scope

Your main imaging scope will be used with your main astro-imaging camera. The main imaging scope can be virtually any scope suitable for your CCD or DSLR camera.

Guide Scope

You will need an additional telescope for guiding, referred to as a guide scope. The guide scope is mounted on top of, or beside the main imaging scope. Adjustable guide scope tube rings (available from Orion) are recommended and allow you to move the guide scope around without moving the main imaging scope. The guide scope is adjusted in the same fashion as a finder scope.

Because of the high resolution and accuracy of the **SAGPRO**, you do not need a large guide scope; any small refractor will serve well for this purpose. Separate refractor optical tube assemblies, such as the Orion Short Tube 80, make excellent guide scopes.

The only exception to using a guide scope is to use an off-axis guider, which is typically made for Schmidt-Cassegrain telescopes. The off-axis guider uses a prism to intercept a small portion of the light path in front of the camera, thus allowing the camera and guider to use the same telescope. Off-axis guiders require a large amount of inward focus travel which is why they are only suitable for Cassegrain type telescopes.

Mount

An **equatorial** mount with dual axis motors and a RJ-12 autoguide port is required. Just about any equatorial mount equipped with an autoguide port will work with the **SAGPRO**. The **SAGPRO** is “ST-4” compatible which uses the same pin out configuration as the first generation CCD autoguiders. Most computerized goto mounts also have this autoguide port. For short exposure deep space photography (typically 45 seconds or less) the **SAGPRO** can successfully guide with a computerized **altitude-azimuth** or fork mounted telescope, popular among computerized Schmidt-Cassegrain telescopes.

However, guided exposures longer than one minute in an **altitude-azimuth** mount will cause field rotation to occur in the image.

PHD Guiding

The **SAGPRO** with the use of **PHD Guiding** (Push Here Dummy) software makes the task of autoguiding simple and easy to setup. The calibration and guiding is automatic once you initially find and focus a guide star. Your telescope must first be prepared for astro-imaging. Make sure your mount is polar aligned well. Your guide scope should be securely attached to your main imaging scope; or if you are using a Schmidt-Cassegrain, the off-axis guider and main camera should already be attached to the telescope.

Note: Autoguiding can correct for a mount that is poorly polar aligned. However the image will be harder to initially locate and center since it will still drift away from the camera’s field of view. Additionally, guiding with a poor polar alignment will eventually cause field rotation in a long exposure image.

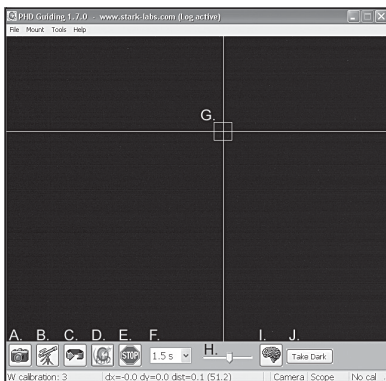

Figure 2. PHD Guiding software.



A. Connect to Camera: Selects and connects to the autoguider camera. Choose **ASCAM** camera. Then select the **CMOS SSAGPro camera** from the menu.



B. Connect to Telescope: To connect the **SAGPRO** to your mount, go to the **Mount** menu and select **On Camera**. The **SAGPRO** will automatically send commands to the autoguide port on your mount once it's plugged in.



C. Looping Exposures: Takes continuous exposures for acquiring and focusing the guide star.



D. PHD Guide: Automatically calibrates and guides. Once your guide star is found and focused, simply click on the star and click **PHD Guide**. The rest is automatic!



E. Stop: Stops either calibrating, guiding, or looping exposures.



F. Exposure Selection: Choose from 14 different exposure times for the camera.



G. Guide Star Box: When a guide star is selected, a green box appears around it. PHD Guiding will display the pixel coordinates of the star in the lower left screen. When the calibration routine starts, yellow crosshairs are displayed around the box. When the autoguiding begins, the crosshairs turn green. This box does not appear until a guide star has been selected. (See **Start Autoguiding**)



H. Gamma Adjustment: Adjust the apparent screen brightness level in the image by moving the slider bar left (brighter) or right (fainter).



I. Advanced Parameters: Control the camera and guiding routine settings. You do not typically have to adjust the advanced parameters. For very bright guide stars, or for daytime testing, the camera gain can be adjusted in this menu. (See **Advanced Autoguider Settings** for more detail about this menu.)



J. Take Dark Frame: Captures and internally saves a dark frame that is automatically subtracted from future exposures. Be sure to cap the scope's objective when taking a dark frame.

Figure 3. PHD Guiding key to icons.

-
1. Locate, center and focus the celestial object you wish to image with your CCD or DSLR camera in your main imaging scope. Once you have centered the desired object, it is important to make sure the tracking on your mount is engaged so you don't lose the object before the guiding starts.
 2. Using a low power 1.25" eyepiece, locate and center a fairly bright star in your guide scope. Do not move the main imaging scope or your object will be lost! We recommend using adjustable guide scope tube rings to allow independent movement of the guide scope.
 3. Remove the eyepiece and insert the **SAGPRO** into your guide scope. The **Par Focal Ring** can be used here to match the focus of the camera to the same as the eyepiece. This makes exchanging eyepiece and camera much easier.
 4. Plug the **SAGPRO** into your computer's USB port and connect the autoguider cable from the **SAGPRO** to your mount's autoguide port.
 5. Run **PHD** Guiding software. Click the **Connect to Camera** icon and choose **ASCOM** then select **CMOS SSAGPro camera**.
 6. Select **Properties** and verify **12bit mode** is unchecked for guiding and also that the Camera gain is set to maximum 100%. This value can be reduced as desired if sensitivity is too high for your particular setup.
 7. In the **Exposure Selection** pull down menu, select **2.0 s**.
 8. Click on the **Looping Exposures** icon to begin continuously taking pictures.
 9. Gradually move the focus inward on your guide scope until you see the star come into focus. As you get close to focused, the camera may start detecting several faint background stars.
 10. Click on the star you want to guide on. A green guide star box should appear around the star you selected. In the lower left corner of **PHD** Guiding, the pixel coordinates of the star will be displayed. If the star is too bright, **PHD** Guiding will warn you with a message at

the bottom of the screen; if so you can choose a fainter guide star or reduce the exposure time.

11. Click the **PHD Guide** icon and the calibration will begin. The rest is automatic! Yellow crosshairs are displayed around the guide star box when the calibration starts. The calibration is automatic and takes a few minutes. When the calibration is complete, the autoguiding begins automatically and the crosshairs turn green. You are now ready to take astro-images with precise tracking!

Note: Be patient while PHD Guiding completes the calibration. The telescope cannot be disturbed during the calibration process. It is just as critical not to touch the telescope during calibration as it is when exposing an astro-image. The calibration ensures that the AutoGuider knows the movements and tracking behaviors of your mount.

Dark Frames and Noise Reduction

All CCD and CMOS cameras have inherent noise which becomes more apparent with longer exposure images. If you require taking longer exposures (typically longer than 3 seconds) you may start to see vertical lines and bright dots (hot pixels). You will get the best guiding performance when your image background looks smooth and black.

The **Gamma Adjustment** will help clip the low level background noise by adjusting the slider bar left or right as needed. You can also reduce the camera **Gain** or enable **Noise Reduction** (see “Advanced Autoguider Settings”).

Take Dark saves a dark frame which is subtracted from your guiding images to remove most of the noise. Dark frames are images taken with the camera capped from incoming light, revealing only the camera noise in the image. This noise is subtracted from a “light frame” which is the image you want to see from the camera.

To take the dark frame:

1. Cap the objective of your guide scope.

-
2. Keep the **Exposure Selection** set to the same time you wish to use for guiding. For example, if you choose **2.0 s**, then you must keep this exposure time while guiding for the dark frame to be effective.
 3. Click **Take Dark**.
 4. Remove the cap from your guide scope and resume taking pictures or guiding. **PHD** Guiding will automatically subtract the dark frames from all of your exposures. To remove the dark frame, go to **Tools** and select **Erase Dark Frame**.

Advanced Autoguider Settings

The **Advanced Parameters** (the brain icon) in **PHD** allows you to change several settings to better customize the guiding performance of your **SAG-PRO**. Under normal use, you should not have to make any major adjustments to the **Advanced Parameters**. All of the calibration and autoguiding is done automatically simply by pressing the **PHD Guide** icon. However the following settings can be adjusted to cater to your specific guiding setup:



Advanced Parameters

R.A. Aggressiveness: Adjusts the percentage of R.A. correction per step. The default value is 100, meaning that the guider will move the full distance of the correction. If the seeing conditions are not steady, the aggressiveness can be turned down to smooth out the quick movements and reduce the correctional movement.

R.A. Hysteresis: Implements a percentage of the previous averaged tracking corrections to the current tracking corrections. This setting can be useful if you are experiencing some wind or severe periodic error, since the guider will partially ignore some of the radical movements and repeat a percentage of the previous tracking corrections.

Dec Guide Mode: Allows Dec guiding to be turned on or off, or switched which side of drift to guide on, or auto which will find the side of drift (N/S).

Dec Algorithm: Settings that attempt to smooth the declination corrections to one consistent movement and can be used to resist switching directions in Dec.

Calibration Step: Adjusts how long each guide pulse is during calibration. The default is 500 milliseconds. The calibration step can be increased to provide a better sample of movement. However, if the calibration step is increased too much, the guide star will move out of the camera's field of view during calibration.

Min. Motion: Number of pixels the star must move before PHD will make a guiding correction. The default is 0.25 pixels.

Search Region: The area in pixels that the guide star is searched for and looked at. The default is 15x15 pixels. Under normal use, this setting should not be changed.

Noise Reduction: Choose from 2x2 mean or 3x3 median to smooth out noise and blur out hot pixels.

Time Lapse: This setting optionally sets a delay between each guiding correction. For mounts that track exceptionally well, you can add a delay between each correction.

Gain: The gain adjusts the camera's internal brightness level and sensitivity. The default is 95%. If you are experiencing excessive noise or hot pixels, you can reduce the gain. The camera remains very sensitive as low as 50% gain. If you are guiding on a very bright guide star, you can afford to turn down the gain and further decrease the noise in your image.

Force Calibration: Enabling this setting makes **PHD** Guide calibrate every time a new star is chosen. If you move your telescope to another object in the sky, you will need to recalibrate the autoguider. The default has this setting enabled.

Log Info: You can log all actions into a text file saved in the **PHD** directory.

Disable Guide Output: This setting deliberately shuts off the autoguider output for potential troubleshooting measures.

Autoguiding Tips & Tricks

If all conditions are ideal, and your tracking is superb, you typically do not have to alter any of the camera's default settings. However, if your setup is tracking much worse than usual (such as a night with high wind or poor

seeing), you may need to customize your settings to better adapt to the current conditions in the field.

Reduce the **R.A. Aggressiveness** in the **Advanced Parameters** menu to better stabilize the guiding during bad seeing or wind gusts. You may also want to decrease the **R.A. Aggressiveness** if your guiding exposures/corrections are set very quickly (less than 1 second). If the guider sends several corrections per second to the mount, the mount's movement may oscillate due to the response time of your mount. Additionally the varying seeing conditions makes the star appear to jump around rapidly and cause the guider to make unnecessary corrections, sometimes referred to as "chasing the seeing". If seeing is poor, keep the guiding correction intervals/exposures to 1 second or more. For most guide scopes, we recommend setting the autoguide exposures between 1-4 seconds for best results.

Polar Alignment

A good polar alignment of your EQ mount is of critical importance for long-exposure imaging. Inaccurate polar alignment leads to field rotation, even with the autoguider tracking. If your equatorial mount uses a polar axis finder scope, we highly recommend utilizing it for polar alignment. If not, a technique known as the "drift method" of polar alignment has been used for many years, and can achieve an extremely accurate polar alignment. Unfortunately it is very time consuming, since the drift of a star over time must be observed. The basic idea is to let the telescope mount track while watching a star to see which way the star drifts. Note the direction of the drift, and correct by moving the mount in the appropriate direction.

To perform the drift method of polar alignment:

1. Do a rough polar alignment by pointing the R.A. axis of the mount at Polaris (the NorthStar).
2. Find a bright star near the meridian (the imaginary line running north-to-south through zenith) and near the celestial equator (zero degrees declination). Point the telescope at this star, and center it in an illuminated reticle eyepiece (available from Orion). If you don't

have an illuminated reticle eyepiece, use your highest- magnification eyepiece.

3. Determine which way is north and south in the eyepiece by moving the telescope tube slightly north and south.
4. Now, let the mount's motor drive run for about five minutes. The star will begin to drift north or south. Ignore any east-to-west movement.
5. If the star drifts north, the telescope mount is pointing too far west. If the star drifts south, the telescope mount is pointing too far east. Determine which way the star drifted and make the appropriate correction to the azimuth position of the mount. Rotate the entire mount (and tripod) slightly east or west as needed or use the azimuth adjustment knobs (if your mount has them) to make fine adjustments to the mount's position.
6. Next, point the telescope at a bright star near the eastern horizon and near the celestial equator (Dec. = 0).
7. Let the telescope track for at least five minutes, and the star should begin to drift north or south.
8. If the star drifts south, the telescope mount is pointed too low. If the star drifts north the telescope mount is pointed too high. Observe the drift and make the appropriate correction to the mount's altitude (or latitude); most mounts have some sort of fine adjustment for this.

Repeat the entire procedure until the star does not drift significantly north or south in the eyepiece after a few minutes. When this is accomplished, you are very accurately polar aligned. Autoguiding on a well polar aligned mount will deliver the best results.

Differential Tube Flexure

A common obstacle in guiding with a separate guide scope and imaging scope is differential tube flexure, the unwanted movement of a guide scope in relation to the main imaging scope. If any part between the autoguider and imager moves or flexes during the exposure, then the resulting image will have oblong stars which gives the appearance of poor tracking. There are a few basic measures to ensure your guide scope is securely in place:

-
1. If your guide scope has a focus lock, firmly tighten the focus lock thumb screw after you have focused on your guide star.
 2. If you are using adjustable guide scope tube rings, make sure all thumb screws are firmly tightened against the guide scope tube.
 3. The guide scope tube rings and mounting plate should be tightened very securely against the main imaging scope. Check for any visual flexure or movement by gently pressing against the guide scope.
 4. The focuser and tube rings on the main imaging scope should also be firmly in place. It is not uncommon for screws and bolts to come loose after a few usages; so they should be checked before each imaging session.

Cabling

The **SAGPRO** uses only two light-weight cables; a USB cable and the autoguider cable. Keep an eye on the cables as you move the scope around. If there is any stress on the cables, your tracking will be affected.

Some imaging cameras use heavy-duty cables with significant weight. These cables can contribute to differential tube flexure. If you are getting images with oblong stars and your tracking appears to be good otherwise, try attaching any heavy cables to a secure location on your mount. It does not take much resistance against the autoguider or imager to create poor tracking.

Planetary Imaging

Planetary imaging is also referred to as Solar System imaging, and includes the Moon, the Sun (with a proper full aperture solar filter!), the planets, and miscellaneous objects in Earth's orbit such as the International Space Station (ISS). The **SAGPRO** is capable of capturing all these objects in real time.

Just about any telescope is suitable for the **SAGPRO** when imaging the planets. The longer the focal length of the telescope, the larger and more

detailed the images will appear. Unlike deep space astro-imaging, you actually want to have a long focal length and focal ratio for planetary imaging.

Download the **Orion AstroCap software guide** for more information on how to use your **SAG PRO** for Planetary Imaging.

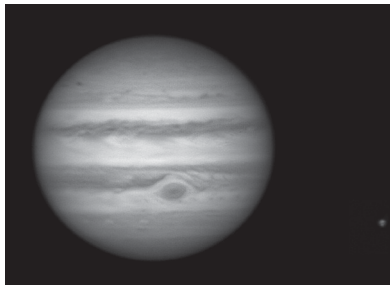

Figure 4. Jupiter and Callisto. Image captured using RGB filters.

Lunar Imaging

Lunar imaging is similar to planetary imaging. Fast exposure times are required due to the high brightness of the moon. Similar techniques used to align and stack planetary images can also be used for lunar image processing.

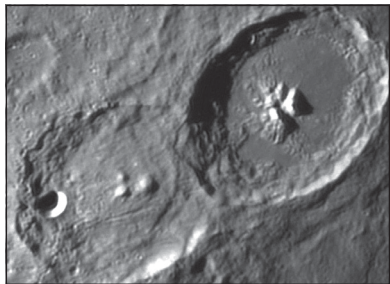

Figure 5. Cyrillus and Theophilus Craters.

Download the **Orion AstroCap software guide** for more information on how to use your **SAG PRO** for Lunar Imaging.

Solar Imaging

Warning: Always use a full aperture Solar Filter when observing the Sun.

With a properly fitting full-aperture solar filter attached to your telescope, you can use the **SAGPRO** to take images of the Sun and the sunspots on its surface. (Filters available through Orion. Check the catalog or OrionTelescopes.com for more information).

Solar imaging, like Planetary and Lunar imaging requires fast frame rates and exposure times.

The **SAGPRO** also functions well using dedicated solar telescopes such as the Coronado PST.

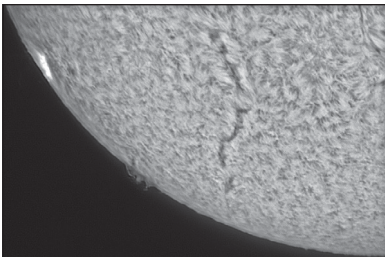

Figure 6. Solar imaging using a Coronado PST.



Figure 7. Deep Space Imaging.

Download the Orion AstroCap software guide for more information on how to use your **SAGPRO** for Solar Imaging.

Deep Space Imaging

Long exposures of up to 10 minutes give the user the ability to capture Galaxies, Clusters, Nebulas, Comets and even asteroids.

Note: Long exposures will require a tracking mount with decent polar alignment. For best results a guide camera should also be used.

Download the Orion AstroCap software guide for more information on how to use your **SAG PRO** for Deep Space Imaging.

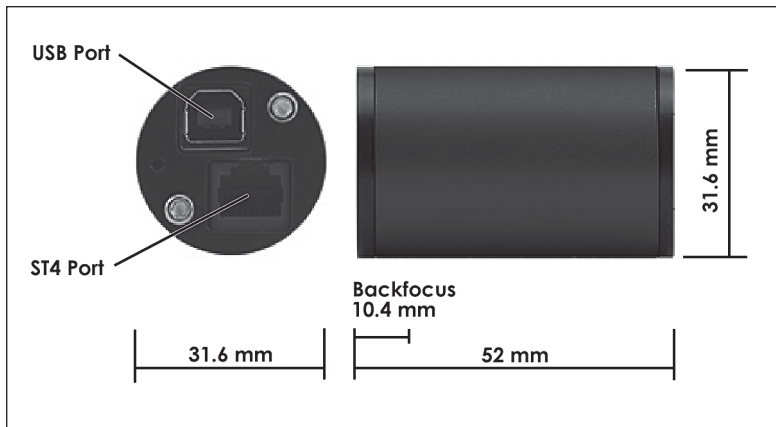

Figure 8. SAGPRO Camera dimensions.

Tips

Choosing a Site for Astro-imaging

Once you have a focused image, you may find your image shifting and washed out. This can be caused by many environmental factors. Poor seeing (movement of molecules in the air, such as heat rising) and poor transparency (moisture, smoke, or other sky contaminants) will all serve to reduce image quality. That is why most major astronomical telescopes are on high mountains in thin air, to get above much of the seeing and transparency problems. Also, wind will move your telescope and affect images. Your eyes viewing through an eyepiece can change slightly to compensate for disturbances like these, but the camera cannot. Keep these factors in mind when choosing an observing site for astronomical imaging.

For the best astro-images, we recommend finding a location with dry air, some altitude, and away from city or streetlights. Even a nearby hilltop in the countryside can provide better viewing conditions than many convenient backyard locations.



- | | | |
|---------|-----------|--------|
| 1. Null | 2. Common | 3. RA+ |
| 4. DEC+ | 5. DEC- | 6. RA- |

Figure 9. Pin out diagram for ST4 Port.

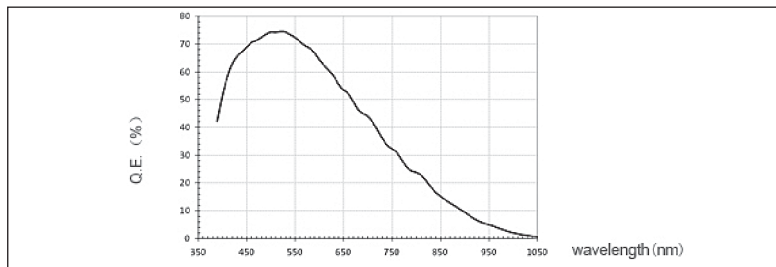

Figure 10. 74% High Quantum Efficiency (QE) of the **SAGPRO**.

Loss of Camera Connection

If the computer connection to the camera is interrupted, you will need to re-establish connection. This can happen due to several reasons; if a cable becomes unplugged, the computer “freezes”, or the software/hardware otherwise temporarily loses the data coming from the camera.

To re-establish camera connection, first close the guiding or capture program that was being used on your computer. Then, unplug and re-plug the camera into the computer’s USB port. Finally, restart the guiding or capture software.

Care and Maintenance

When the **SAGPRO** is not in use, the dust cap should be replaced on the end of the nosepiece. This prevents dust from accumulating on the **SAGPRO**’s optical window. The optical window should only be cleaned if significant dust builds up or if the window is touched. Any quality optical lens cleaning tissue and optical lens cleaning fluid specifically designed for multi-coated optics can be used to clean the glass surface of the **SAGPRO**’s optical window. Never use regular glass cleaner or cleaning fluid

designed for eyeglasses. Before cleaning with fluid and tissue, blow any loose particle off the surface with a blower bulb or compressed air. Then apply some cleaning fluid to a tissue, never directly on the optics. Wipe the optical surface gently in a circular motion, then remove any excess fluid with a fresh lens tissue. Use caution, rubbing too hard may cause scratches.

(Cleaning products available through Orion, check the catalog or OrionTelescopes.com for more information).

Specifications

Camera Sensor:	Aptina Mono CMOS MT9M034
Sensor format:	1/3"
Pixel array:	1280 x 960 (1.2Mp)
Pixel Size:	3.75 μ m x 3.75 μ m
Exposure Range:	0.02 sec to 10 Minutes
Max Frame Rate:	30FPS @ 1280x960 44 FPS @ 1024x768 75FPS @ 800x600 106 FPS @640x480 200 FPS @320x240
A/D Conversion:	On chip 14bit (8 bit output)
Thermoelectric cooling:	No
IR Cut filter:	No
Mounting:	1.25" nose piece
Weight (oz.):	45g
Dimensions:	31.6mm diameter x 52mm long
Mount connection:	Via RJ-12 modular jack (6-pin)
Autoguide commands:	"ST-4" output

***Note: Max frame rate dependent upon resolution, output format, exposure, USB speed, CPU speed and hard drive speed.**

One-Year Limited Warranty

This Orion product is warranted against defects in materials or workmanship for a period of one year from the date of purchase. This warranty is for the benefit of the original retail purchaser only. During this warranty period Orion Telescopes & Binoculars will repair or replace, at Orion's option, any warranted instrument that proves to be defective, provided it is returned postage paid. Proof of purchase (such as a copy of the original receipt) is required. This warranty is only valid in the country of purchase.

This warranty does not apply if, in Orion's judgment, the instrument has been abused, mishandled, or modified, nor does it apply to normal wear and tear. This warranty gives you specific legal rights. It is not intended to remove or restrict your other legal rights under applicable local consumer law; your state or national statutory consumer rights governing the sale of consumer goods remain fully applicable.

For further warranty information, please visit www.OrionTelescopes.com/warranty.



Corporate Offices: 89 Hangar Way, Watsonville CA 95076 - USA

Toll Free USA & Canada: (800) 447-1001

International: +1(831) 763-7000

Customer Support: support@telescope.com

Copyright © 2020 Orion Telescopes & Binoculars. All Rights Reserved. No part of this product instruction or any of its contents may be reproduced, copied, modified or adapted, without the prior written consent of Orion Telescopes & Binoculars.