

## INSTRUCTION MANUAL

# Orion® 6", 8", and 10" F/4 Newtonian Astrographs

#10269 - 6" f/4

#9505 - 8" f/4

#10271 - 10" f/4



**ORION**  
**TELESCOPES & BINOCULARS**  
AN EMPLOYEE-OWNED COMPANY

**Corporate Offices:** 89 Hangar Way, Watsonville CA 95076 - USA  
**Toll Free USA & Canada:** (800) 447-1001  
**International:** +1(831) 763-7000  
**Customer Support:** [support@telescope.com](mailto:support@telescope.com)

*Copyright © 2021 Orion Telescopes & Binoculars. All Rights Reserved. No part of this product instruction or any of its contents may be reproduced, copied, modified or adapted, without the prior written consent of Orion Telescopes & Binoculars.*

# Table of Contents

Parts List	3
Getting Started	3
Operating the F/4 Newtonian Astrograph	6
Collimating the Optics	7
Care & Maintenance	11
Specifications	12

*Congratulations on your purchase of the Orion® f/4 Newtonian Astrograph. These telescopes feature fast, high-quality parabolic optics; a machined, dual-speed Crayford focuser with linear-track bearing; and excellent mechanical construction. The 6", 8", and 10" f/4 Newtonian Astrographs have been specially optimized for astrophotography with DSLR and astronomical imaging cameras. This manual covers all three astrographs. Other than their apertures, they are similar; any significant differences among them will be noted. These instructions will help you set up and use your telescope.*

**WARNING:** *Never look directly at the Sun with the naked eye or with a telescope – unless you have a proper solar filter installed over the front of the telescope! Otherwise, permanent, irreversible eye damage may result.*



**Figure 1.** Components of the Orion F/4 Newtonian Astrographs

---

## Parts List

- Optical tube assembly
- Cooling fan (8" and 10" only, installed)
- Battery holder for cooling fan (8" and 10" only)
- Eyepiece adapter, 2" to 1.25" (installed in focuser)
- 8x50 finder scope
- Finder scope bracket and O-ring
- Tube rings (x2)
- Dovetail mounting bar
- M6 x 1.0 socket head cap screws (x2)
- Extension tube adapter, 35mm length
- Collimation cap
- Hex wrenches – 2.5mm and 5mm
- Dust cap

## Getting Started

Your f/4 Newtonian Astrograph arrives nearly fully assembled from the factory. The optics were collimated at the factory, however you should check the collimation prior to first use (see “Collimating the Optics”) as, not uncommonly after shipment, an adjustment may be necessary.

We recommend that you keep all of the original packaging. In the unlikely event you should need to ship the telescope back to Orion for warranty repair service, you should use the original packaging to ensure the telescope stays intact during shipping.

When unpacking the telescope, refer to the Parts List above and **Figure 1** to make sure everything is accounted for. Then refer to **Figure 2** to familiarize yourself with some of the features and components of the telescope.

### Connecting the Telescope to a Mount

The f/4 Newtonian Astrographs each come with a pair of hinged, felt-lined tube rings to hold the optical tube assembly (OTA). Each ring has a flat riser on opposite sides. The taller riser (on the bottom of the tube ring) bears a single M6 x 1.0 metric threaded hole. The other, flatter riser (top of tube ring) has a ¼"-20 threaded hole in the center.

Attach the dovetail bar to the bottom of the tube rings using the included M6 x 1.0 socket head cap screws and the corresponding 5mm Allen wrench (**Figure 3**). We recommend using the through holes on the ends of the dovetail bar to put the bolts through for tube ring attachment, although you could also use one or both of the slots in the bar. For the 6" optical tube, the tube rings should straddle the focuser, as shown in **Figure 4A**. For the 8" and 10" f/4 astrographs, both tube rings should be positioned between the focuser and the rear of the optical tube for proper balance (**Figure 4B**). The included dovetail bar fits mounts with a Vixen-style dovetail saddle.

The flat risers on the top side of the tube rings can be used to attach an optional dovetail bar for piggybacking another telescope or a guide scope for astrophotography. You will need

to purchase the appropriate length ¼"-20 bolts to attach an optional dovetail bar to the rings.

### Balancing the Optical Tube on a Mount

The optical tube must be balanced on both the right ascension and declination axes of an equatorial mount for proper tracking and guiding. Balancing the F/4 Newtonian Astrographs is achieved by sliding the dovetail mounting plate forward or backward in the mount's dovetail saddle. You can also move the telescope forward or backward within the tube rings. To do that, loosen the tube ring clamps slightly and slide the telescope tube forward or backward as needed to reach optimum balance, then retighten the tube ring clamps. Rotating the telescope to achieve a comfortable eyepiece or camera angle is done in the same fashion. Simply loosen the tube ring clamps just enough to allow the optical tube to rotate within the tube rings. Retighten the tube ring clamps securely once you have reached the desired eyepiece or camera orientation.

### Dual-Speed Crayford Focuser with Linear Track Bearing

The F/4 Newtonian Astrographs feature a machined aluminum, dual-speed Crayford-type focuser (**Figure 5**) that incorporates a linear track bearing design. The 6" and 8" f/4 have a 2" focuser and the 10" f/4 boasts a 3.3" focuser. The linear bearing eliminates drawtube play and enables support of heavier loads without slippage. If the drawtube does slip under the weight of your imaging system or heavy visual accessories, simply increase the drawtube tension by gently tightening the drawtube tensioning thumbscrew as needed.

The smooth focus motion and fine-focus wheel allow precision adjustments for critical focusing of eyepieces and cameras. Once you have reached focus, you can lock the drawtube in place by tightening the focus lock thumbscrew.

The focuser drawtube has 50mm of travel and English and metric hash marks, which allow you to note the drawtube position at the precise focus point so you can return to it when you need to.

### Using 1.25" and 2" Accessories

The 2" focuser can accommodate both 1.25" and 2" accessories, including just about any eyepiece or camera. Both the 2" holder and removable 1.25" adapter feature a brass compression ring to hold your accessories in place without marring their metal barrels.

The bottom of the 1.25" eyepiece adapter is threaded to accommodate 2" Orion filters. But with a filter installed, be careful when inserting an eyepiece or Barlow lens into the adapter for the first time, to make sure the barrel is not long enough to contact the filter – which could scar or crack it. If the eyepiece or Barlow is too long, then it would be better to thread a 1.25" filter into the barrel of the eyepiece or Barlow itself, if it is threaded to accept one.

### Fine Focus

The focuser features both coarse and fine focusing wheels. The two large, silver-colored wheels are for coarse focusing. The small black wheel next to the large focus wheel on the right side allows ultra-precise focus adjustment at a gear ratio

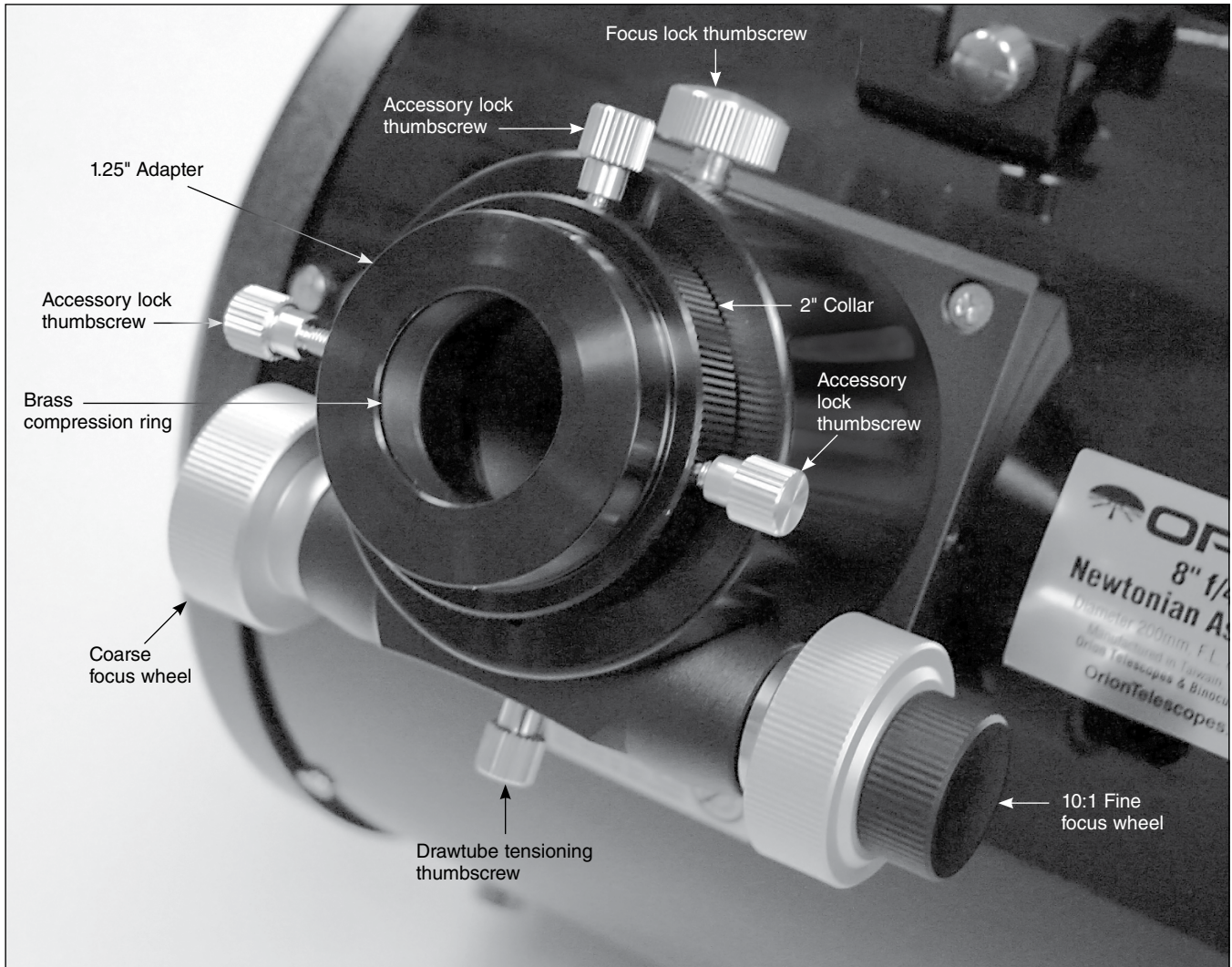

**Figure 2.** The dual-speed 2" Crayford-type linear bearing focuser

of 10:1, meaning ten turns of the fine focus wheel equals one turn of the large focus wheel.

Use the large focus wheels to achieve rough focus on your target object, then use the fine focus wheel to home in on the exact focus point. You will be amazed at the amount of detail that careful fine focus adjustment brings in to view on targets such as the lunar surface, planets, double stars, as well as other celestial objects.

### Attaching the Finder Scope

The included 8x50 crosshair finder scope (**Figure 6**) is useful for locating objects in the sky and centering them in the main telescope's field of view.

To install it, first remove the O-ring from the bracket and place it over the body of the finder scope until it seats in the narrow groove near the middle of the finder. Unthread the two black nylon alignment screws on the bracket until the screw ends are flush with the inside surface of the bracket. Slide the eyepiece end (narrow end) of the finder scope into the end of the bracket's cylinder opposite the alignment screws while pulling the

chrome, spring-loaded tensioning pin on the bracket with your fingers (**Figure 6A**). Push the finder scope through the bracket until the O-ring seats just inside the front opening. Release the tensioner and tighten the two black nylon screws a couple of turns each to secure the finder scope in place. The tips of the tensioner and nylon screws should seat into the wide groove on the finder scope's body.

Now slide the foot of the finder scope bracket into the dovetail base on the main telescope (**Figure 6B**). You'll first have to back out the thumbscrew lock on the dovetail base a few turns to allow the bracket to slide in. Once the bracket is inserted, tighten the thumbscrew lock.

### Aligning the Finder Scope

The finder scope and the main telescope must be aligned so they point to exactly the same spot in the sky. Alignment is easiest to do in daylight. First, insert an eyepiece (a crosshair eyepiece is best) into the 35mm extension adapter and insert the adapter into the telescope's focuser. (If you're using a 1.25"-diameter eyepiece, you insert its barrel into the focus-



**Figure 3.** Attach the tube rings to the dovetail bar using the provided socket head cap screws and 5mm Allen wrench.



**A**



**B**

**Figure 4. (A)** For the 6" model we recommend that the tube rings straddle the focuser as shown to allow proper balance. **(B)** For the 8" and 10" models both tube rings are positioned to the rear of the focuser

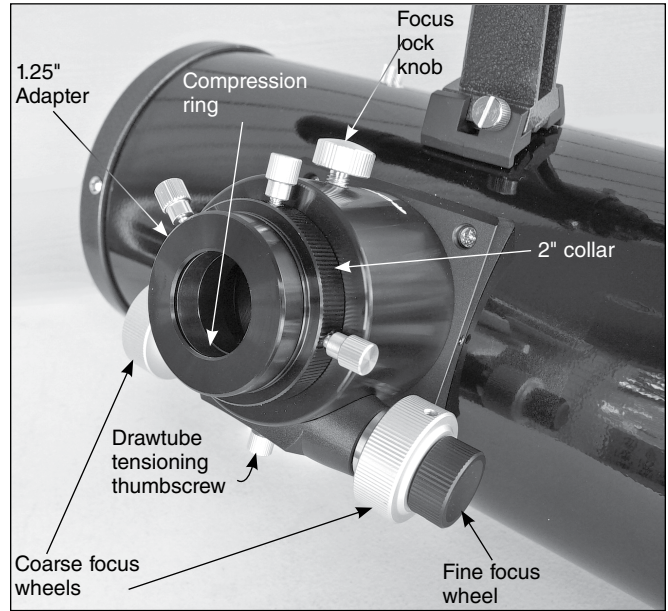

**Figure 5.** The aluminum 2" dual-speed linear bearing focuser.

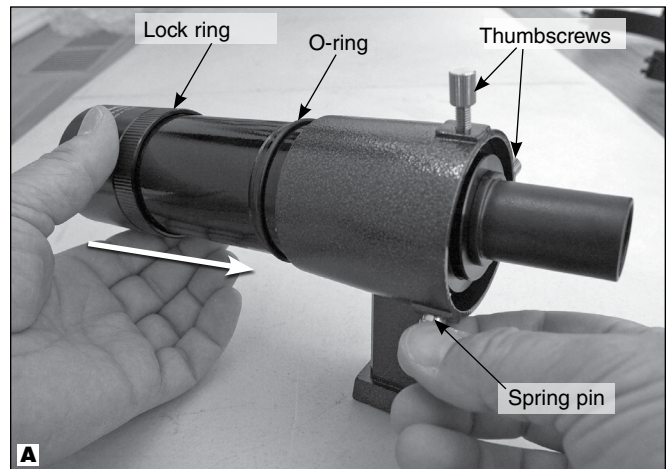

**A**

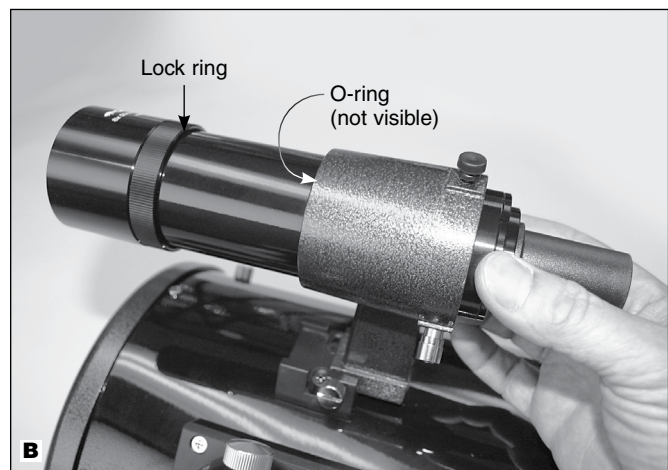

**B**

**Figure 6. (A)** Insert the finder scope into the bracket. **(B)** Slide the finder scope bracket into the dovetail base.

---

er's 1.25" adapter, then insert that into the 35mm extension adapter.) You'll need the 35mm extension adapter to reach focus with most eyepieces. Point the telescope at an object such as the top of a telephone pole or a street sign that is at least a quarter-mile away. Move the telescope so the target object appears in the very center of the field of view when you look into the eyepiece.

Now look through the finder scope. Is the object centered in the finder scope's field of view? If not, hopefully it will be visible some-where in the field of view, so that only a minor adjustment of the finder scope's two alignment screws will be needed to center it. Otherwise you'll have to make coarser adjustments to redirect the aim of the finder scope.

Once the target object is centered on the crosshairs of the finder scope, look again in the telescope's eyepiece and see if it is still centered there as well. If it isn't, repeat the entire process, making sure not to move the telescope while adjusting the alignment of the finder scope. When the target object is centered on the crosshairs of the finder scope and in the telescope's eyepiece, the finder scope is aligned and ready to be used for locating objects.

The finder scope alignment should be checked before every imaging or observing session. This can easily be done at night, before viewing through the telescope. Choose any bright star or planet, center the object in the telescope eyepiece, and then adjust the bracket's alignment screws until the star or planet is also centered on the finder's crosshairs.

### **Focusing the Finder Scope**

If the image in the finder scope appears out of focus, you will need to refocus the finder scope for your vision. First, loosen the lock ring located behind the objective lens cell on the body of the finder scope (See **Figure 6B**). Back the lock ring off by a few turns. Then refocus the finder scope on a distant object by rotating the objective lens cell clockwise or counterclockwise. Once the image appears sharp, retighten the lock ring behind the objective lens cell. The finder scope's focus should not need to be adjusted again.

## **Operating the F/4 Newtonian Astrograph**

Your F/4 Newtonian Astrograph is designed primarily for astrophotography, but it makes a fine visual instrument as well. For visual use, we recommend using high-quality eyepieces to take full advantage of the instrument's exceptional optical quality. For imaging applications, the telescope is optimized for use with an APS-C or smaller sensor, found in such cameras as the Orion StarShoot G10 Deep Space Color imaging Camera and StarShoot G26 APS-C Color Imaging Camera as well as crop-sensor DSLRs and mirrorless cameras.

### **Cooling the Telescope**

All optical instruments need time to reach "thermal equilibrium." The bigger the instrument and the larger the temperature change, the more time is needed. Allow at least 30 minutes for your telescope to cool to the temperature outdoors. In very

cold climates (below freezing), it is essential to store the telescope as cold as possible. If it has to adjust to more than a 40°F temperature change, allow at least one hour. You can use the telescope while it's cooling down, just note that you may see "tube currents," which interfere with the telescope's ability to resolve a sharp image. Tube currents are essentially heat waves exiting both the optical components (such as the primary mirror) and the telescope itself. The effect seen through the eyepiece is much like looking above a hot surface or fire.

### **Mirror Cooling Fan**

The 8" and 10" F/4 Newtonian Astrographs come with a cooling fan installed on the rear of the primary mirror cell (**Figure 7**). Using the fan reduces the amount of time required for the large primary mirror to reach thermal equilibrium with the ambient air. The fan is powered by 12-volts DC. The included battery holder holds eight AA alkaline batteries (not included). Plug the cable from the battery holder into the fan's power jack located on the rear cell. Alternatively, the fan can be powered by a 12-volt DC field battery, such as the Orion Dynamo Pro.

You can run the fan prior to starting your imaging or observing session, then turn it off, or keep it running during the session, as there should be no noticeable vibration. However, it is probably not necessary to run the fan continuously for long periods of time, unless the temperature is changing continuously and rapidly.

### **Imaging with Your F/4 Newtonian Astrograph**

The f/4 Newtonian Astrographs have fast F/4 parabolic optics, which produce bright images and allow fairly short exposure times. Fast optics also inherently produce some coma, or distortion of star images toward the periphery of the field of view. Therefore, to achieve the best possible images, we recommend using a coma corrector (sold separately). The coma corrector is attached to the focuser drawtube in front of the camera body. Use of a coma corrector will allow you to utilize the entire imaging area of your camera without the need to crop the edges of your astro-images. Check Orion's website for compatible coma correctors.

### **Attaching a CCD Camera**

Most dedicated astronomical cameras have a 1.25" or 2" barrel, or a nosepiece that allows attachment directly to your telescope's focuser like an eyepiece. No adapter is required. Simply insert the nosepiece of the camera into the 1.25" or 2" eyepiece holder and secure the camera with the thumbscrew lock (**Figure 8**).

If your astro camera does not include a compatible nosepiece, or if you wish to utilize the camera's T-threads, a zero-profile prime focus camera adapter is required (available from Orion). The zero-profile adapter has male T-threads that couple to the female T-threads of your camera. The adapter's 2" barrel is inserted and secured in the focuser just like a 2" eyepiece.

### **Attaching a DSLR Camera**

To attach a DSLR camera, you will need the appropriate T-ring for the make and model of your camera and a zero-profile prime focus camera adapter (available from Orion). Simply attach the T-ring to the camera body and thread the zero-pro-

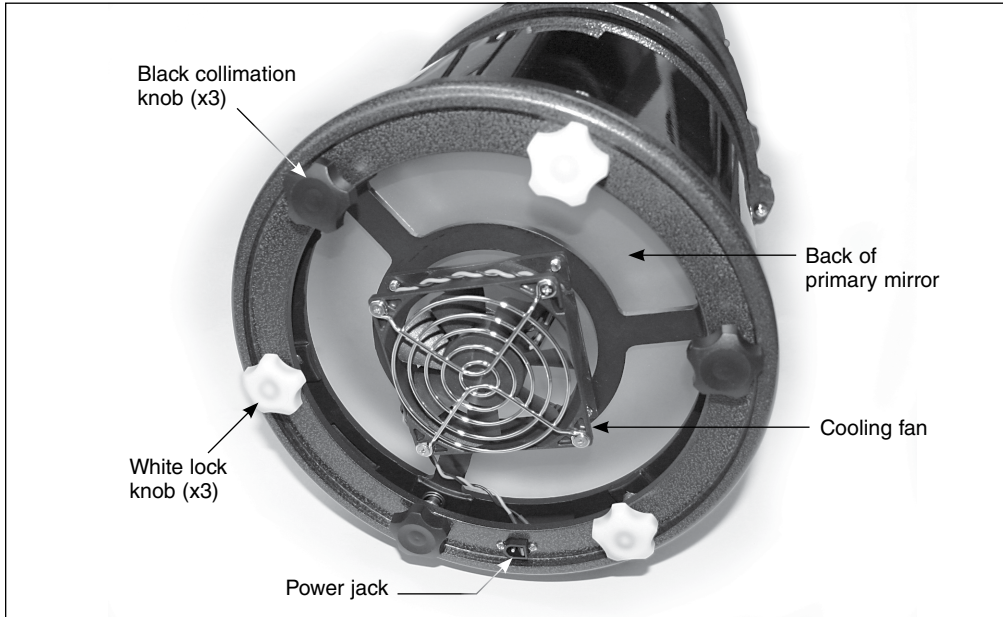

**Figure 7.** Rear of telescope showing the installed cooling fan and six collimation adjustment knobs (three black collimation knobs and three white lock knobs).

file camera adapter onto the threads of the T-ring. Then insert the barrel of the camera adapter into the focuser's 2" eyepiece holder (or an optional coma corrector) and secure it with the two thumbscrew locks (**Figure 9**).

### Visual Observing with the 8" F/4 Newtonian Astrograph

To achieve focus with a telescope eyepiece, you will likely have to use the included 35mm-long extension adapter (**Figure 10**). Just insert it into the 2" collar on the focuser and tighten the two thumbscrews to secure the extension adapter in place. The insert either a 2" eyepiece or a 1.25" eyepiece (using the 1.25" adapter) into the 35mm extension adapter.

## Collimating the Optics (Aligning the Mirrors)

Collimating is the process of adjusting the mirrors so they are aligned with one another. Your telescope's optics were aligned at the factory, and should not need much adjustment unless

the telescope was handled roughly in transit. Accurate mirror alignment is important to ensure the peak performance of your telescope, so it should be checked regularly. Collimating is a relatively easy process and can be done in daylight or darkness.

To check collimation, remove the eyepiece and look down the focuser drawtube. You should see the secondary mirror centered in the drawtube, as well as the reflection of the primary mirror centered in the secondary mirror, and the reflection of the secondary mirror (and your eye) centered in the reflection of the primary mirror, as in **Figure 11A**. If anything is off-center, proceed with the following collimating procedure.

### The Collimation Cap

Your F/4 Newtonian Astrograph comes with a "quick collimation cap" (**Figure 12**). This is a simple cap that fits on the focuser draw-tube like a dust cap, but has a tiny hole in the center and small black ring on the underside. The collimation cap helps



**Figure 8.** To use an astronomical CCD or CMOS camera with the 8" f/4.0 Newtonian Astrograph, the camera must have a 1.25" or 2" nosepiece, which is inserted into the accessory collar in the focuser. An external camera adapter with compatible threads could be used in lieu of the nosepiece.

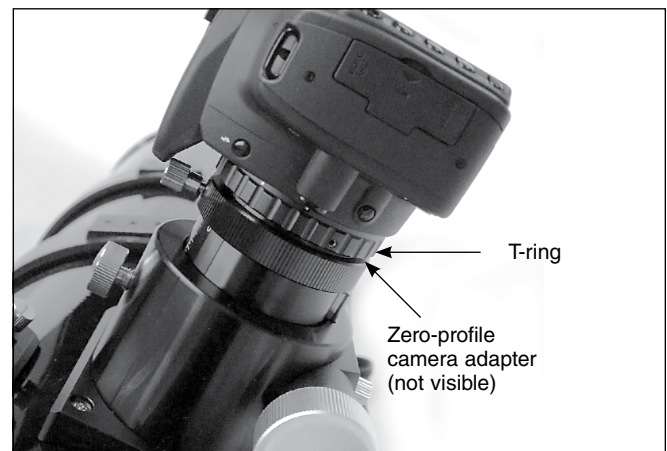

**Figure 9.** Attachment of a DSLR camera requires a T-ring for the particular camera model and a T-adapter, such as the Orion Zero-Profile Prime Focus Camera Adapter, which fits into the 2" accessory collar.

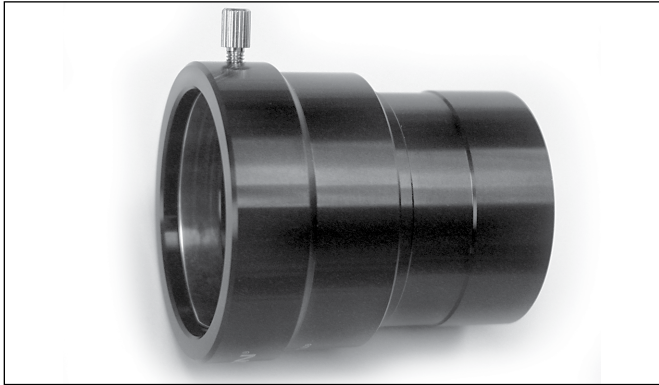

**Figure 10.** The 35mm extension adapter adds 35mm of length to the focuser drawtube. It is needed to reach focus for visual use of the 8" F/4.0 Newtonian Astrograph.

center your eye over the focuser drawtube so that aligning the optical components is easier to achieve. The black ring provides a distinct visual reference that is helpful in centering the primary and secondary mirror reflections. **Figures 11B** through **11E** assume that you have the collimation cap in place.

### The Primary Mirror Center Mark

You'll notice that the primary mirror of the F/4 Newtonian Astrograph has a tiny ring (sticker) marking its center. This "center mark" allows you to achieve a very precise collimation of the primary mirror; you don't have to guess where the exact center of the mirror is.

*NOTE: The center ring sticker need not ever be removed from the primary mirror. Because it lies directly in the shadow of the secondary mirror, its presence in no way adversely affects the*

*optical performance of the telescope or the image quality. That might seem counterintuitive, but it's true!*

### Preparing the Telescope for Collimating

Once you get the hang of collimating, you will be able to do it quickly even in the dark. For now, it is best to collimate in daylight, preferably in a brightly lit room and aimed at a white wall. It is recommended that the telescope tube be oriented horizontally. This will prevent any parts from the secondary mirror from falling down onto the primary mirror and causing damage if something comes loose while you are making adjustments. Place a sheet of white paper inside the optical tube directly opposite the focuser (**Figure 13**). The paper will provide a bright "background" when viewing into the focuser.

### Aligning the Secondary Mirror

To adjust the secondary mirror collimation, you will need both a small and a large Phillips screwdriver.

You will need to check, and adjust if necessary, four aspects of the secondary mirror's alignment:

1. The secondary mirror's axial position
2. The secondary mirror's radial position
3. The secondary mirror's rotational position
4. The secondary mirror's tilt

The first three will probably only need to be checked and (possibly) adjusted once. Thereafter, it is usually only the secondary mirror's tilt that will need to be adjusted occasionally.

### Adjusting the Secondary Mirror's Axial Position

With the collimating cap in place, look through the hole in the cap at the secondary (diagonal) mirror. Ignore the reflections

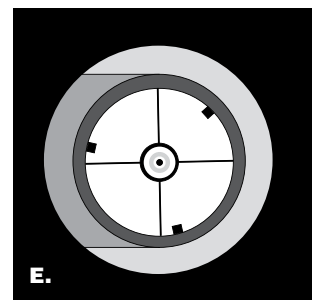
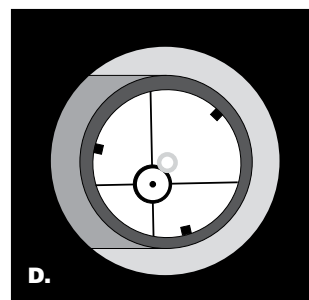
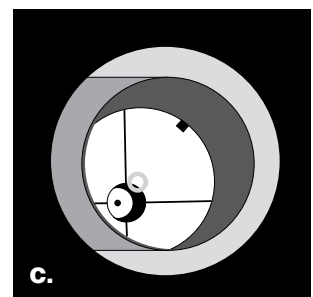
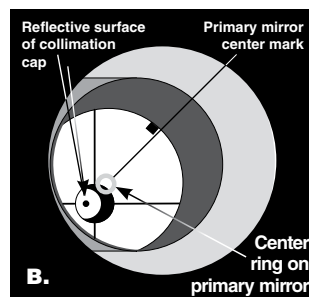
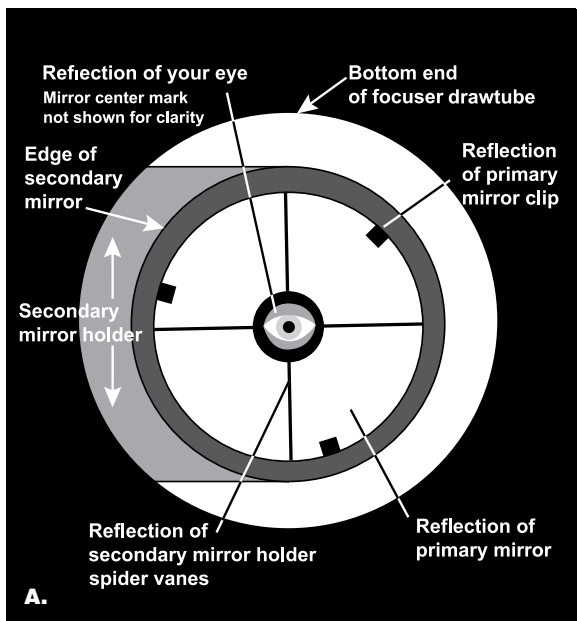
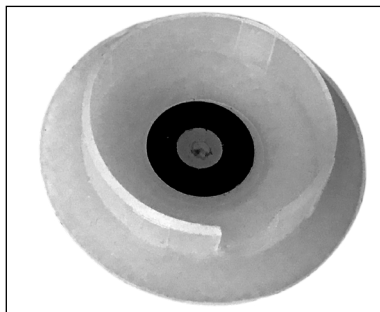

**Figure 11.** Collimating the optics. **(A)** When the mirrors are properly aligned, the view down the focuser drawtube should look like this. **(B)** With the collimation cap in place, if the optics are out of alignment, the view might look something like this. **(C)** Here, the secondary mirror is centered under the focuser, but it needs to be adjusted (tilted) so that the entire primary mirror is visible. **(D)** The secondary mirror is correctly aligned, but the primary mirror still needs adjustment. When the primary mirror is correctly aligned, the center "dot" of the collimation cap will be centered, as in **(E)**.



for the time being. The secondary mirror itself should be centered in the focuser drawtube. If it is off-center along the axis of the telescope, i.e., positioned too far toward the front opening or toward the rear of the telescope, as it is in **Figure 11B**, you will have to adjust the mirror's axial position.

To do so, use a small Phillips screwdriver to loosen the three small alignment set screws in the center hub of the 4-vane



**Figure 12.** The quick collimation cap, which features a black ring on the underside, helps in centering reflections of the optics in the focuser during the collimation process.

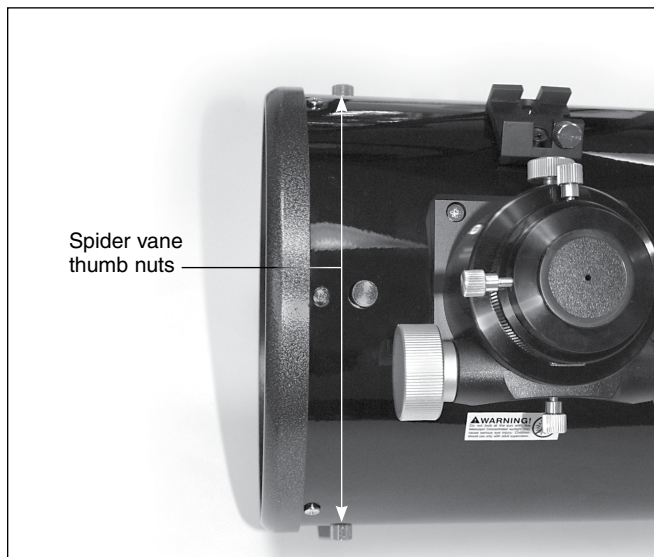

**Figure 13.** Placing a piece of white paper inside the optical tube opposite the focuser provides a bright background when viewing into the focuser.

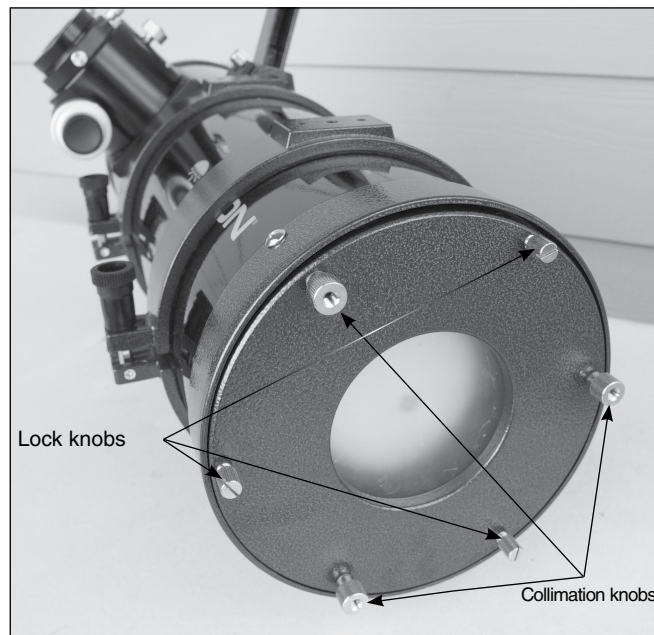

**Figure 14.** To center the secondary mirror axially under the focuser, hold the secondary mirror holder in place with your fingers while adjusting the center screw with a large Phillips-head screwdriver. Later you will adjust the tilt of the secondary mirror by turning the three small set screws that surround the large center screw.

spider several turns. Now, grasp the mirror holder (the cylinder that is attached to the back of the secondary mirror itself) with one hand while turning the center screw with a large Phillips head screwdriver with your other hand (**Figure 14**). Turning the screw clockwise will move the secondary mirror toward the front opening of the optical tube, while turning the screw counter-clockwise will move the secondary mirror toward the primary mirror. When the secondary mirror is centered axially in the focuser drawtube, rotate the secondary mirror holder until the reflection of the primary mirror is as centered in the secondary mirror as possible. It may not be perfectly centered, but



**Figure 15.** To center the secondary mirror radially in the focuser drawtube, make adjustments to the two knurled spider vane thumbnuts that are perpendicular to the focuser.



**Figure 16.** On the 6" F/4, the larger, spring-loaded collimation knobs are used to adjust the primary mirror tilt, while the thinner knobs lock the mirror in place. Loosen each lock knob a couple turns before adjusting the collimation knobs.

that is fine for now. Then, tighten the three small alignment set screws equally to secure the secondary mirror in that position.

### Adjusting the Secondary Mirror's Radial Position

Like the axial position, the secondary mirror's radial position was set at the factory and will probably not need any adjusting, or if it does, you'll typically need to do it only once.

By "radial position" we mean the position of the secondary mirror along the axis perpendicular to the focuser drawtube. This position is changed by adjusting two of the spider vane thumb nuts, as shown in **Figure 15**. Loosen one thumb nut, then tighten the opposite one until the secondary mirror is centered radially in the drawtube. Do not loosen the thumb nuts too much, to avoid having them completely unthread from the ends of the spider vanes. Also, when making this adjustment, be careful not to stress the spider vanes or they could bend.

### Adjusting the Secondary Mirror's Rotational Position

The secondary mirror should face the focuser squarely. If the mirror appears to be rotated away from the focuser, the mirror's rotational position will need to be adjusted. Again, this adjustment will rarely, if ever, need to be done.

Grip the sides of the secondary mirror holder with your fingers. Then, using a large Phillips screwdriver, loosen the center screw in the secondary mirror holder about a quarter of a turn only (counterclockwise). That should be enough to free up the secondary mirror to rotate slightly in either direction. Look into the collimation cap and rotate the mirror slightly in each direction to get an idea of how it affects the view of the secondary mirror. Now rotate the mirror as needed so that it precisely faces the focuser. Hold the mirror holder stationary in that position while turning the center screw clockwise until it is just tight (do not over-tighten). Sometimes the mirror may rotate slightly when tightening the screw, so keep at it until the mirror faces the focuser squarely and is secured in place.

### Adjusting the Secondary Mirror's Tilt

Finally, the tilt of the secondary mirror may occasionally require adjustment. If the entire primary mirror reflection is not visible in the secondary mirror when using the collimation cap, as in **Figure 11C**, you will need to adjust the tilt of the secondary mirror. Using a small Phillips head screwdriver, first loosen one of the three alignment set screws by, say, one full turn, and then tighten the other two to take up the slack. Do not loosen the center screw during this process. The goal is to center the primary mirror reflection in the secondary mirror, as in **Figure 11D**. When it is centered, you're done adjusting the secondary mirror. Don't worry that the reflection of the secondary mirror (the dark circle with the four spider vanes adjoining it) is off-center, since that adjustment is made when aligning the primary mirror in the next step.

### Aligning the Primary Mirror

The final collimation adjustment is made to the primary mirror. It will need adjustment if, as in **Figure 11D**, the secondary mirror is centered under the focuser and the reflection of the primary mirror is centered in the secondary mirror, but the reflection of the secondary mirror (dark circle containing the

light reflective surface and center black "dot" of the collimation cap) is off-center.

The tilt of the primary mirror is adjusted with three spring-loaded collimation bolts on the rear end of the optical tube (bottom of the primary mirror cell). For the 8" and 10" f/4 models, the spring-loaded collimation bolts are each fitted with a black knob (**Figure 7**). The alternating white knobs are attached to lock bolts, which secure the mirror in place once the correct tilt has been achieved. For the 6" f/4 model, the three large knobs are the spring-loaded collimation knobs, while the thinner knobs (thumbscrew heads) with the screwdriver slot in them are the lock knobs (**Figure 16**).

To adjust the primary mirror's tilt, first loosen all three lock knobs by turning them counterclockwise about one turn each. Now, while looking into the focuser through the collimation cap, turn one of the collimation knobs a half turn or so in either direction and see if the secondary mirror reflection moves closer to the center of the primary. That is, does the "dot" of the collimation cap appear to move closer to the ring on the center of the primary mirror? If it does, great, keep going until you get it as close as you can. If it doesn't, try turning the collimation knob in the opposite direction. If turning the one knob does not seem to bring the dot closer to the ring, try using one of the other collimation knobs. It will take some trial-and-error using all three collimation knobs to properly align the primary mirror. Over time you will get the feel for which collimation screws to turn to move the image in a given direction.

When you have the dot centered as much as possible in the ring, your primary mirror is collimated. Now lightly tighten the three lock knobs to secure the primary mirror in that position.

The view through the collimation cap should now resemble **Figure 11E**. A simple star test will indicate how well the telescope optics are collimated.

### Star-Testing the Telescope

When it is dark, point the telescope at a bright star and accurately center it in the eyepiece's field of view. (To achieve focus with an eyepiece, you will likely have to use the included 35mm extension adapter, as described previously.) Slowly defocus the image with the focusing knob. If the telescope is correctly collimated, the expanding disk should be a perfect circle (**Figure 17**). If the image is unsymmetrical, the scope is out of collimation. The dark shadow cast by the secondary mirror

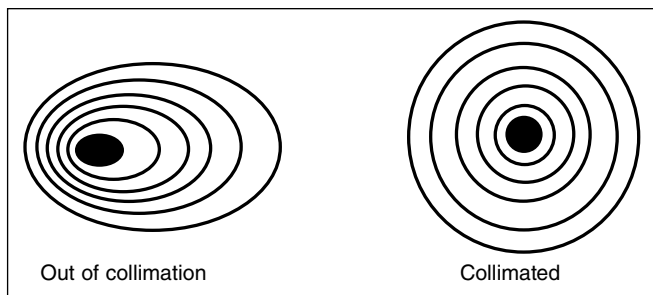

**Figure 17.** A star test will determine if the telescope's optics are properly collimated. A defocused view of a bright star through the eyepiece should appear as illustrated on the right if the optics are perfectly collimated. If the circle is unsymmetrical, as illustrated on the left, the optics need alignment.



**Figure 18.** To clean the primary mirror, you must remove the mirror in its cell from the telescope tube. To do so, remove the six Phillips-head screws that fasten the rear cell to the tube. Then separate the cell from the tube.

should appear in the very center of the out-of-focus circle, like the hole in a donut. If the “hole” appears off-center, the telescope is out of collimation.

If you try the star test and the bright star you have selected is not accurately centered in the eyepiece, the optics will always appear out of collimation, even though they may be perfectly aligned. It is critical to keep the star centered, so over time you will need to make slight corrections to the telescope’s position in order to account for the sky’s apparent motion. Point the telescope at Polaris (the north star) if you do not have a mount that tracks.

## Care & Maintenance

Give your telescope reasonable care and it will last a lifetime. When not in use, keep its dust cover on as well as the dust cap on the eyepiece opening. Keep the telescope inside the hard storage carrying case when not in use. Store it indoors or in a dry garage. Do not leave the telescope outside except when using it. The optical tube is aluminum and has a smooth anodized surface that should resist scratches and smudges. If a scratch does appear on the tube, it will not harm the telescope. Smudges on the tube can be wiped off with standard household cleaners such as Windex or Formula 409.

## Cleaning Mirrors

In general, your telescope’s mirrors will only need to be cleaned very infrequently, if ever. Covering the front opening of the telescope with the dust cover when it is not in use will prevent dust from accumulating on the mirrors. Keeping the dust cap on the focuser’s 1.25" opening is also a good idea. Improper cleaning can scratch the mirror coatings, so the fewer times you have to clean the mirrors, the better. Small specks of dust or flecks of paint have virtually no effect on the visual or imaging performance of the telescope.

The large primary mirror and the elliptical secondary mirror of your telescope are front-surface aluminized and over-coated with hard silicon dioxide, which prevents the aluminum from oxidizing. These coatings normally last through many years of use before requiring re-coating.

To clean the secondary mirror, first remove it from the telescope. Do this by keeping the secondary mirror holder stationary while completely unthreading the Phillips-head screw in the center hub of the spider vane assembly. Do not touch the mirror surface when doing this. Once the Phillips-head screw is unthreaded, the secondary mirror and its holder can be removed from the telescope. The secondary mirror does not need to be removed from its holder for cleaning. Then follow the same procedure described below for cleaning the primary mirror.

To clean the primary mirror, first carefully remove the mirror cell from the telescope. To do so you must remove the six screws on the exterior of the mirror cell (**Figure 18**). Then pull the cell away from the tube. You will notice the primary mirror is held in the mirror cell with three clips held by two screws each. Loosen the screws and remove the clips.

You may now remove the primary mirror from its cell. Do not touch the surface of the mirror with your fingers. Lift the mirror carefully by the edges. Set the mirror on a clean soft towel. Fill a clean sink or large bucket with room temperature water, a few drops of liquid dishwashing detergent, and if possible, a capful of 100% isopropyl alcohol. Submerge the mirror (aluminized surface facing up) in the water and let it soak for a few minutes (or hours if it’s a very dirty mirror). Wipe the mirror under water with clean cotton balls, using extremely light pressure and stroking in straight lines across the mirror surface. Use one ball for each wipe across the mirror. Then rinse the mirror under a stream of lukewarm water. Any particles on the surface can be swabbed gently with a series of cotton balls, each used just one time. Dry the mirror surface with a stream of air (a “blower bulb” works great). Cover the mirror surface with tissue, and leave the mirror in a warm area until it is completely dry before replacing it in the mirror cell. Then reinstall the mirror cell in the telescope optical tube with the six screws.

---

## Specifications

### 6" f/4 Newtonian Astrograph

Optical configuration:	Newtonian reflector
Aperture:	150mm (5.9")
Focal length:	610mm
Focal ratio:	F/4.1
Primary mirror:	BK-7 optical glass, parabolic figure, center marked
Mirror coatings:	Enhanced aluminum (94% reflectivity) with SiO <sub>2</sub> overcoat
Secondary mirror minor axis:	62.5mm
Backfocus distance:	77.1mm (from 2" drawtube collar)
Focuser:	Dual-speed (10:1) 2" linear bearing Crayford, with 1.25" adapter
Drawtube travel:	50mm
Optical tube:	Rolled steel, gloss black enamel finish
Tube rings:	Included, hinged, felt-lined
Finder Scope:	8x50, with dovetail bracket
Extension tube:	35mm length, 2" compression ring holder
Weight, assembled:	12.9 lbs. (5.85 kg)
Length:	22.8" (58.0cm)

### 8" f/4 Newtonian Astrograph

Optical configuration:	Newtonian reflector
Aperture:	200mm (7.9")
Focal length:	800mm
Focal ratio:	F/4.0
Primary mirror:	BK-7 optical glass, parabolic figure, center marked
Mirror coatings:	Enhanced aluminum (94% reflectivity) with SiO <sub>2</sub> overcoat
Secondary mirror minor axis:	70mm
Back focus distance:	83.2mm (from 2" drawtube collar)
Focuser:	Dual-speed (10:1) 2" linear bearing Crayford, with 1.25" adapter
Drawtube travel:	50mm
Optical tube:	Rolled steel, gloss black exterior finish
Tube rings:	Included, hinged, felt-lined
Finder Scope:	8x50, with dovetail bracket
Extension tube:	35mm length, 2" compression ring holder
Cooling Fan:	Included, requires 8 AA batteries (not included)
Weight, assembled:	19.0 lbs., 15.7 oz. (9.06 kg)
Length:	27.9" (71.0cm)

---

### **10" f/4 Newtonian Astrograph**

Optical configuration:	Newtonian reflector
Aperture:	250mm (9.8")
Focal length:	1000mm
Focal ratio:	F/4.0
Primary mirror:	BK-7 optical glass, parabolic figure, center marked
Mirror coatings:	Enhanced aluminum (94% reflectivity) with SiO <sub>2</sub> overcoat
Secondary mirror minor axis:	88mm
Back focus distance:	92.4mm (from 2" drawtube collar)
Focuser:	Dual-speed (10:1) 3.3" linear bearing Crayford, with 1.25" adapter
Drawtube travel:	50mm
Optical tube:	Rolled steel, gloss black exterior finish
Tube rings:	Included, hinged, felt-lined
Finder Scope:	8x50, with dovetail bracket
Extension tube:	35mm length, 2" compression ring holder
Cooling Fan:	Included, requires 8 AA batteries (not included)
Weight:	33 lbs., 12.3 oz. (15.32 kg)
Length:	38.4" (97.5cm)

---

*Page left blank intentionally*

---

*Page left blank intentionally*

---

## One-Year Limited Warranty

This Orion product is warranted against defects in materials or workmanship for a period of one year from the date of purchase. This warranty is for the benefit of the original retail purchaser only. During this warranty period Orion Telescopes & Binoculars will repair or replace, at Orion's option, any warranted instrument that proves to be defective, provided it is returned postage paid. Proof of purchase (such as a copy of the original receipt) is required. This warranty is only valid in the country of purchase.

This warranty does not apply if, in Orion's judgment, the instrument has been abused, mishandled, or modified, nor does it apply to normal wear and tear. This warranty gives you specific legal rights. It is not intended to remove or restrict your other legal rights under applicable local consumer law; your state or national statutory consumer rights governing the sale of consumer goods remain fully applicable.

For further warranty information, please visit [www.OrionTelescopes.com/warranty](http://www.OrionTelescopes.com/warranty).



**Corporate Offices:** 89 Hangar Way, Watsonville CA 95076 - USA  
**Toll Free USA & Canada:** (800) 447-1001  
**International:** +1(831) 763-7000  
**Customer Support:** [support@telescope.com](mailto:support@telescope.com)

*Copyright © 2021 Orion Telescopes & Binoculars. All Rights Reserved. No part of this product instruction or any of its contents may be reproduced, copied, modified or adapted, without the prior written consent of Orion Telescopes & Binoculars.*